

# Differential pressure switches for air, flue and exhaust gases

## Pressure switch for gas

**DUNGS®**

**LGW...A4**  
**LGW...A4/2**

**5.08**



### Technical description

The differential pressure switch LGW...A4 is an adjustable differential pressure switch for automatic burner controls.

It is suitable for switching a circuit on, off or over on changes in actual pressure value relative to the set reference value.

The reference value (switching point) is adjusted on a setting wheel provided with a scale. The test nipple is integrated in metal housing as standard.

### Application

Differential pressure monitoring in firing, ventilation and air-conditioning systems.

Differential pressure switches: suitable for air, flue and exhaust gases.

Pressure switches: suitable for gases of families 1,2,3 and other neutral gaseous media.

### Approvals

EC type test approval as per EC Gas Appliance Directive:

LGW...A4	CE-0085 AQ 0673
LGW...A4/2	CE-0085 AQ 0673

EC type test approval as per EC Pressure Equipment Directive:

LGW...	CE0036
--------	--------

Approvals in other important gas-consuming countries.

TÜV (German Technical Inspectorate) test as pressure switch; special construction type as per TRD 604 and VdTÜV leaflet, Edition 100/1, as well as Class "S" as per EN 1854.

### Functional description

Differential pressure switch in pressure and vacuum ranges. The differential pressure acts via the diaphragm against the force of the setting spring on the microswitch. The pressure switch operates without any auxiliary power.

### Differential pressure switch LGW...A4

The switching mechanism responds to differential pressure which acts between the two pressure chambers. It switches an electric circuit on, off or over when the set reference value is exceeded or undershot.

### Overpressure switch LGW...A4

#### Pressure connection G 1/4

The switching mechanism responds if there is an overpressure which switches on, off or over to an electric circuit if the set reference value is exceeded or undershot.

Single-acting pressure switch in the overpressure range. The pressure connection G 1/8 may not be closed.

### Vacuum switch LGW...A4

#### Pressure connection G 1/8

The switching mechanism responds to vacuum which switches an electric circuit on, off or over when the set reference value is exceeded or undershot. Single-acting pressure switch in vacuum range. The pressure connection G 1/4 may not be closed.

#### LGW...A4 switching function

##### As pressure rises:

1 NC opens, 2 NO closes

##### As pressure falls:

1 NC closes, 2 NO opens

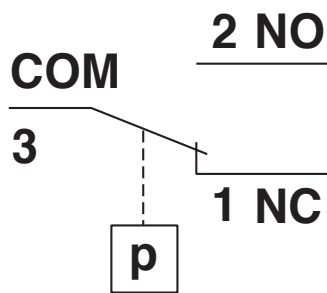

#### Definition of switching difference $\Delta p$

The switching difference  $\Delta p$  is the pressure difference between the upper and lower switching pressures.

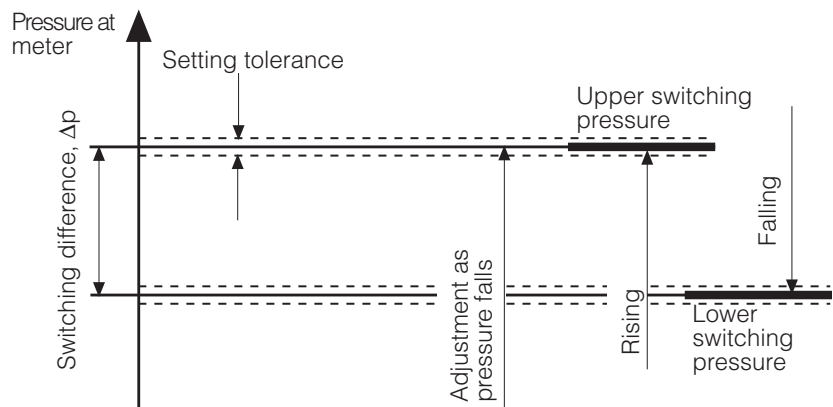

#### LGW...A4, Design: Clear cover

##### Protection class: IP 54

- IP 54**
- 5** Protection against ingress of solid particles  $\varnothing \geq 1$  mm.  
Protection against access to hazardous parts using  $\varnothing \geq 1$  mm wire  
Complete contact protection
  - 4** Protection against a water jet.  
No hazardous conditions may result.

#### LGW...A4/2, Design: Metal housing

##### Protection class: IP 65

- IP 65**
- 6** Protection against the entry of dust (dust sealed).  
Protection against access to hazardous parts using  $\varnothing \geq 1$  mm wire  
Complete contact protection
  - 5** Protection against a water jet from a nozzle directed at the unit (housing) from any directions  
No hazardous conditions may result (water jet).

## Specifications

Max. operating pressure	LGW 3 A4 - LGW 150 A4	500 mbar (50 kPa)		
	LGW 3 A4/2 - LGW 150 A4/2	500 mbar (50 kPa)		
Pressure connection	P+: G 1/4 female thread ISO 228 on centre of housing underside: <b>gas or air</b> P+: G 1/4 screw plug on side of housing: <b>gas or air</b> P-: G 1/8 female thread ISO 228 on side of housing underside: <b>only air</b>			
Measuring connection	Instrument gland integrated in metal housing, $\varnothing$ 9			
Temperature range	Ambient temperature:	-15 °C to +70 °C		
	Medium temperature:	-15 °C to +70 °C		
	Storage temperature:	-30 °C to +80 °C		
Materials	<b>LGW...A4</b>			
	Housing base	aluminum die casting		
	Hood	Polycarbonate		
	Switch	Polycarbonate		
	Diaphragms	NBR		
	Switching contact	Standard: Ag Optional: Ag gold-plated (Au), suitable for DDC applications: 24 VDC; 0.02 A		
	<b>LGW...A4/2</b>			
	Housing base	Diecast aluminum		
	Hood	Extrusion cast zinc, powder-coated		
	Switch	Polycarbonate		
	Diaphragms	NBR		
	Switching contact	Standard: Ag Optional: Ag gold plated (Au), Suitable for DDC applications: 24 VDC; 0.02 A		
Switching voltage	Ag contact	AC eff.	min. 24 V	max. 250 V
		DC	min. 24 V	max. 48 V
	Au contact	DC	min. 5 V	max. 24 V
Nominal current	Ag contact	AC eff.	10 A	
	Au contact	DC	20 mA	
Switching current	Ag contact	AC eff.	min. 20 mA	max. 6 A bei $\cos \varphi$ 1
		AC eff.	min. 20 mA	max. 3 A bei $\cos \varphi$ 0,6
		DC	min. 20 mA	max. 1 A
	Au contact	DC	min. 5 mA	max. 20 mA
Electrical connection	Standard	at screw terminals via M20 x 1.5 cable gland		
	Special design	plug connection for line sockets as per DIN EN 175 301-803, 3-pin with protection contact		
Degree of protection	LGW...A4	IP 54 as per IEC 529 (EN 60529), (transparent hood)		
	LGW...A4/2	IP 65 as per IEC 529 (EN 60529), (metal housing)		
Adjustment	If pressure increases in vertical installation position. Optionally adjustment for rising or falling pressure possible on site. If installation position deviates, note change in switch point.			
Setting tolerance	$\pm$ 15% switch point deviation referred to reference value and installation in vertical position.			
Reference value setting device	Standard: blue Version "Y": Yellow			

## Dimensions [mm]

### LGW... A4

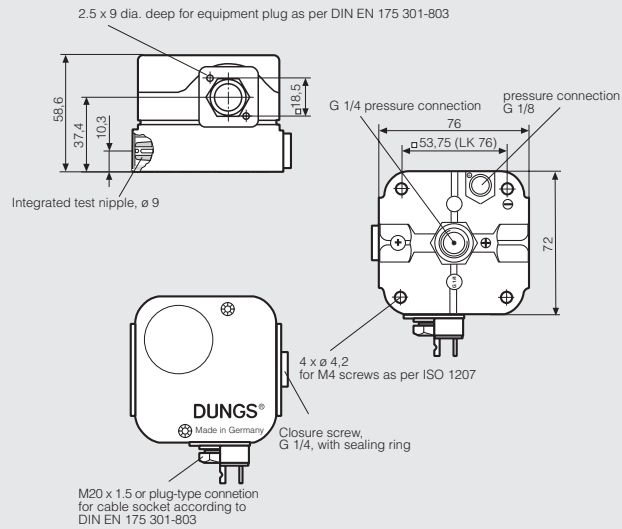

### LGW... / ...A4

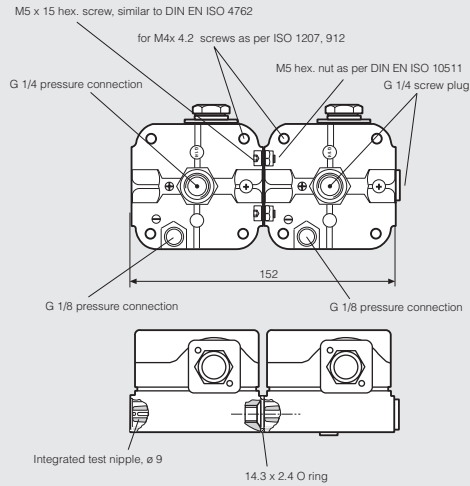

### LGW... A4/2

with metal housing,  
cable gland M 20 x 1.5

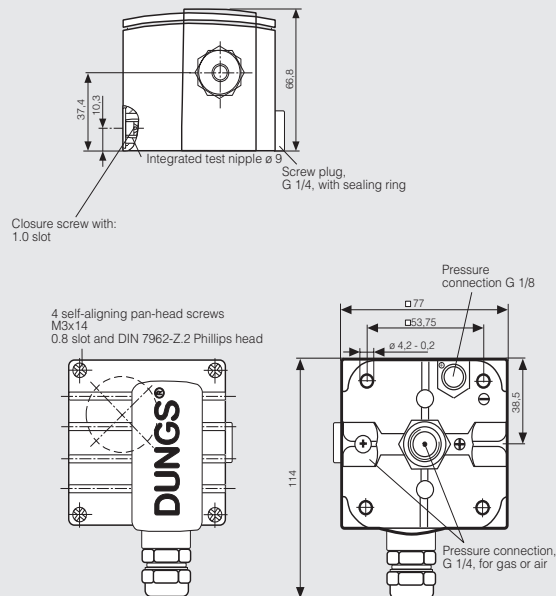

### LGW... A4/2

with metal housing, plug-in connection for sockets accord. to DIN EN 175 301-803

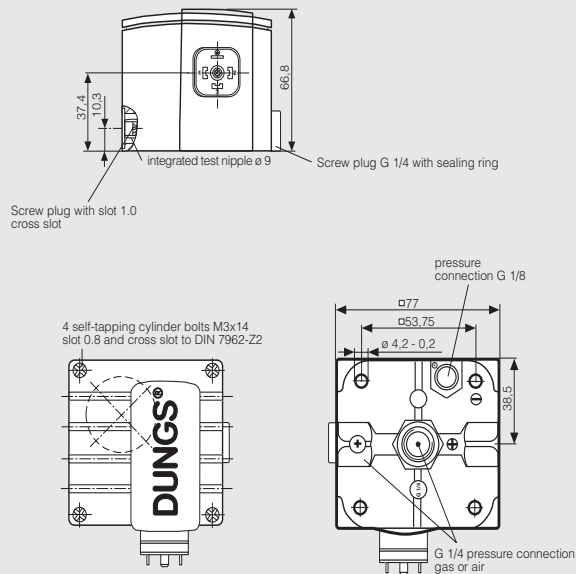

## Installation position

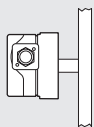

**Standard installation position**

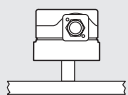

**When installed horizontally, the pressure switch switches at a pressure higher by approx. 0.5 mbar**

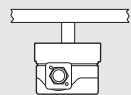

**When installed horizontally overhead, the pressure switch switches at a pressure lower by approx. 0.5 mbar**

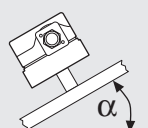

**When installed in an intermediate installation position, the pressure switch switches at pressure deviating from the set reference value by max. ± 0.5 mbar.**

## Designation

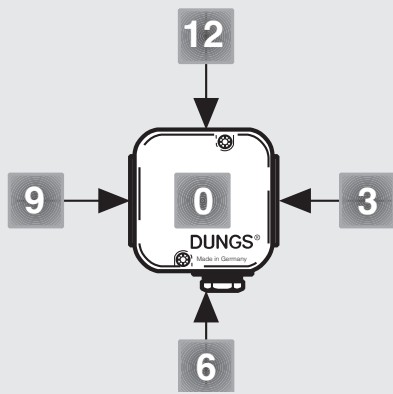

## LGW 3 A4 [Y-Ag-M-MS9-V0-VS3]

→	<b>Pressure connection</b>	
	V0	Pressure connection G 1/4 position 0
	V3	Pressure connection G 1/4 position 3
→	<b>screw plug</b>	
	VS0	screw plug at position 0
	VS3	screw plug at position 3
→	<b>Test nipple</b>	
	MS3	Test nipple at position 3
	MS9	Test nipple at position 9
	M9	Test nipple, open position 9
→	<b>Electrical connection</b>	
	M	M20 x 1.5 cable gland
	G 3	Device connector
→	<b>Contact material</b>	
	Ag	
	Au	
→	<b>Version</b>	
	Y	Gas model (yellow reference value setting device)
→	<b>Adjustment ranges [mbar]</b>	
	0,4 - 3	
	1 - 10	
	2,5 - 50	
	30 - 150	
→	<b>Pressure switch design</b>	
	LGW...A4	Clear cover, PC, (IP 54) Differential pressure switch switches when the pressure exceeds or drops below the adjusted setpoint.
	LGW...A4/2	Metal housing, powder-coated, (IP 65) Differential pressure switch switches when the pressure exceeds or drops below the adjusted setpoint.

## Order example

### Pressure switch design

LGW...A4 differential pressure switch

### Setting range

30 - 150 mbar

### Contact material

Ag

### Electrical connection

Cable gland M20 x 1.5

### Test nipple

MS 9

### Pressure connection G 1/4

V0-VS3; at position 0 and position 3 with closure screw

## LGW 150 A4 [Ag-M-MS9-V0-VS3]

## Accessories for

### LGW...A4 pressure switch

## Order No.

Kit: G3 equipment plug, 3-pin + E	219 659
Line sockets, 3-pin + E grey GDMW	210 318
G 1/4 test nipple and seal ring (5 x)	230 398
G 1/4 screw plug and seal ring (5 x)	230 396
Double pressure switch mounting kit (not for /2-version)	213 910
Metal mounting bracket	230 288
G 1/4 screw-in glands, only for air	230 279
G 1/8 screw-in glands, only for air	230 278
Mounting kit glowlamp , 230 V yellow	231 773
Mounting kit glowlamp, 120 V yellow	231 772
Mounting kit display-LED, 24 V yellow	231 774
Mounting kit glowlamp, 230 V green	248 239
Mounting kit display-LED, 24 V yellow	248 240

**Differential pressure switches  
for air, flue and exhaust gases  
Pressure switch for gas**

**LGW...A4  
LGW...A4/2**

**DUNGS®**

**Technical Summary** 1 mbar = 100 Pa = 0.1 kPa ≈ 10 mm WS

1 Pa = 0.01 mbar ≈ 0.1 mm WS

Model	Version [Ag-M-MS9-V0-VS3]	Order No.	Setting range [mbar]		Degree of protection	Differential pressure switch $\Delta p$ [mbar]
<b>LGW...A4</b> Differential pressure switch	LGW 3 A4	221 590	0,4 - 3		IP 54	≤ 0.3
	LGW 10 A4	221 591	1 - 10		IP 54	≤ 0.5
	LGW 50 A4	221 592	2,5 - 50		IP 54	≤ 1
	LGW 150 A4	221 593	30 - 150		IP 54	≤ 3
Supplied in collective packaging						

Model	Version [Ag-M-MS9-V0-VS3]	Order No.	Setting range [mbar]		Degree of protection	Differential pressure switch $\Delta p$ [mbar]
<b>LGW...A4/2</b> Differential pressure switch	LGW 3 A4/2	232 041	0,4 - 3		IP 65	≤ 0.3
	LGW 10 A4/2	232 046	1 - 10		IP 65	≤ 0.5
	LGW 50 A4/2	232 048	2,5 - 50		IP 65	≤ 1
	LGW 150 A4/2	232 050	30 - 150		IP 65	≤ 3
Supplied in separate packaging						

Model	Version [Ag-G3-MS9-V0-VS3]	Order No.	Setting range [mbar]		Degree of protection	Differential pressure switch $\Delta p$ [mbar]
<b>LGW...A4/2</b> Differential pressure switch	LGW 3 A4/2	232 716	0,4 - 3		IP 65	≤ 0.3
	LGW 10 A4/2	232 717	1 - 10		IP 65	≤ 0.5
	LGW 50 A4/2	232 718	2,5 - 50		IP 65	≤ 1
	LGW 150 A4/2	232 719	30 - 150		IP 65	≤ 3
Supplied in separate packaging including line socket						

Model	Version [Y-Ag-M-MS9-V0-VS3]	Order No.	Setting range [mbar]		Degree of protection	Differential pressure switch $\Delta p$ [mbar]
<b>LGW...A4</b> Differential pressure switch	LGW 3 A4 Y	242 864	0,4 - 3		IP 54	≤ 0.3
	LGW 10 A4 Y	242 865	1 - 10		IP 54	≤ 0.5
	LGW 50 A4 Y	242 866	2,5 - 50		IP 54	≤ 1
	LGW 150 A4 Y	242 867	30 - 150		IP 54	≤ 3
Supplied in collective packaging						

We reserve the right to make any changes in the interest of technical progress.

**Head Offices and Factory  
Karl Dungs GmbH & Co. KG  
Siemensstraße 6-10  
D-73660 Urbach, Germany  
Telefon +49 (0)7181-804-0  
Telefax +49 (0)7181-804-166**

**Postal address  
Karl Dungs GmbH & Co. KG  
Postfach 12 29  
D-73602 Schorndorf, Germany  
e-mail info@dungs.com  
Internet www.dungs.com**